

2012 T-1000S Operating manual



1、 T-1000S System features

- 1、 32—256 Gray level, Support software Gamma correction。
- 2、 Support the rules and special-shaped handle.
- 3、 Single-port output, can support 2048 pixels。
- 4、 Off-line(SD Card) control, play back content stored in the SD card.
- 5、 T-1000S store a maximum of 16 programs, copy multiple files to the SD card in order, after formatting the SD card as “FAT” format.
- 6、 The program must be named in orders . just as : 00_1.led, 01_1.led, 02_1.led.
- 7、 Compatible with single line or double line chips.

NOTE: 1. When T-1000S controller control less than 512 lamps the frame rate can reach 30fps. When T-1000S control more than 512 lamps and less than 2048 lamps the frame rate will slow down automatically.

2. T-1000S must use the new software LedEdit 2012.

2、 Support chips:

Chip type	Software code& Controller type	Lamps/(MA X)	Note
LPD6803,D705,1101,6909, 6912	T-1000-6803	2048 pixels	
LPD8806,LPD8809	T-1000-8806	2048 pixels	
TM1803,TM1804,TM1809,T M1812	T-1000-TM	2048 pixels	TM1804 and TM1809 are divided into high and low
TM1903, TM1904, TM1909, TM1912	T-1000-TM19	2048 pixels	
UCS6909 , UCS6912 , UCS7009, UCS5903	T-1000-UCS-32	2048 pixels	
UCS1903 , UCS1909 , UCS1912	T-1000-UCS-256	2048 pixels	1903 and 1909 are divided into high and low
UCS3903	T-1000-UCS-1024	2048 pixels	
DMX512	T-1000-DMX	170/512 pixels	Compatible with standard DMX512
WS2801,WS2803	T-1000-WS	2048 pixels	
WS2811	T-1000-WS2811	2048 pixels	WS2811 be divided into high and low
DS189	T-1000-DS189	2048 pixels	
TLS3001,TLS3002, TLS3008	T-1000-TLS	* pixels	
P9813	T-1000-P9813	2048 pixels	
SM16715	T-1000-SM16715	2048 pixels	SM16715 be divided into high and low
SM16716	T-1000-SM16716	2048 pixels	
BS0901,BS0902	T-1000-0901	2048 pixels	
BS0815	T-1000-0815	2048 pixels	

3、Appearance picture



4、Definition of printing:

Buttons	Meaning	
保存 SET	Save Settings (to save current settings file and the playback speed)。	
模式 MODE	Change programs	
速度 SPEED+	Speed up	Press speed+ and speed- at the same time the program will play circularly.
速度 SPEED-	Speed down	

DC5V	+5V power input
GND	Power GND input
7.5-24V	+7.5-24V power input
电源灯 POWER	Power indicator
错误灯 ERROR	Error indicator
SD卡 SD CARD	SD card slot

TTL signal (245/spi signal):

RS485 signal.

CLK	Clock signal	B	Signal A / DMX+
DAT	Data signal	A	Signal B / DMX-
GND	Signal ground	GND	Signal ground

NOTE: For the TTL(SPI) signal, the controller signal ground must connect to the LED ground directly.

5、 Mode of connection

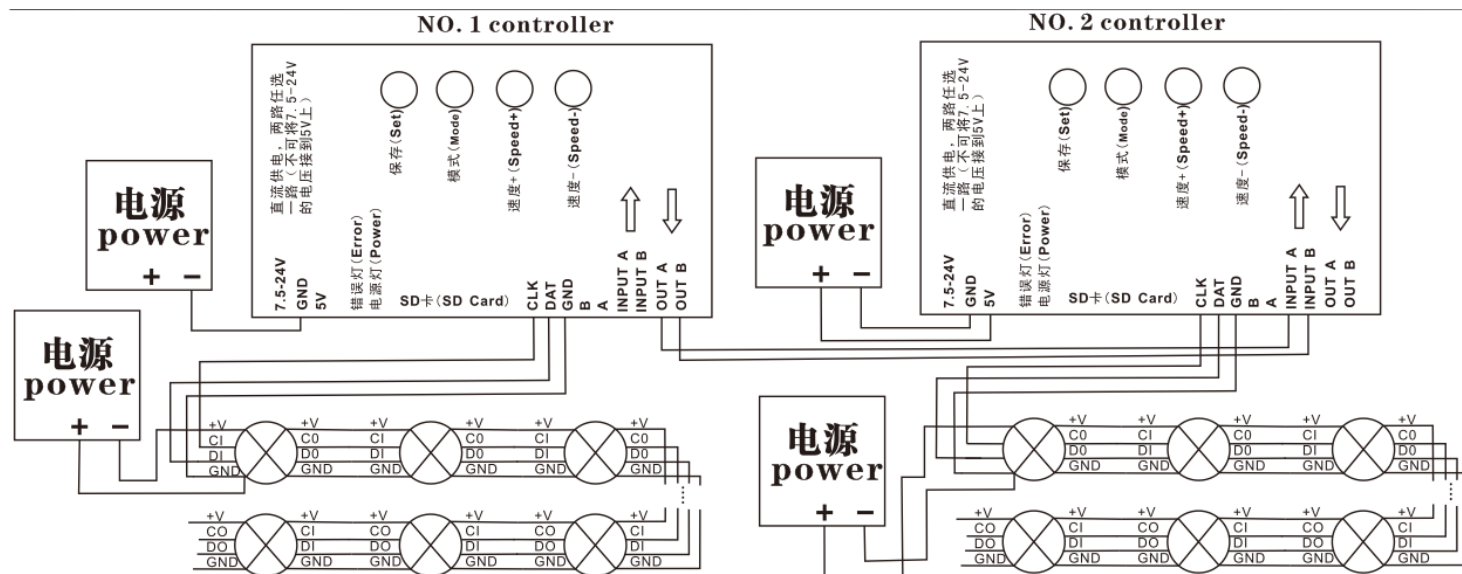

when the controller control less than 512 pixels the frame rate can reach 30fps,
when control more than 512 pixels the frame rate will slow down automatically.

1. Multiple T-1000S controllers can be cascaded together and work synchronously.
2. T-1000S one TTL(SPI) signal and one RS485 signal port output, can control 2048 pixels/lamps;
3. When the chip for LED is single line chip just with data, then just need to be connected with DAT and GND of the controller. If the chip for LED is double line chip with DAT and CLK, then need to be connected with DAT, CLK, and GND of the controller.
4. If you need to use RS485 signal you need to connect controller **A interface** with LED lamps A (DMX+), controller **B interface** with LED lamps B(DMX-),
5. If you need to control a new IC type by the controller, software code mode is: **T-1000-IC model**.

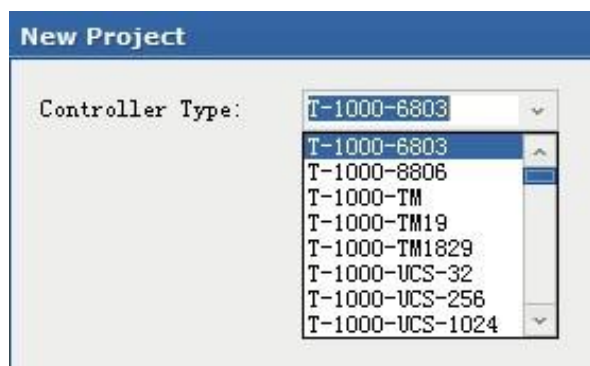

6、 Name of the program: (The rule of how to name the programs:)

The name for NO.2 controller:

“00_1.led” ----- NO.1 program for No.1 controller

“01_1.led” ----- NO.2 program for No.1 controller

“02_1.led” ----- NO.3 program for No.1 controller

.....

“15_1.led” ----- NO.16 program for No.1 controller

The name for NO.2 controller:

“00_2.led” ----- NO.1 program for No.2 controller

“01_2.led” ----- NO.2 program for No.2 controller

“02_2.led” ----- NO.3 program for No.2 controller

.....

“15_2.led” ----- NO.4 program for No.2 controller

.....

PIC:

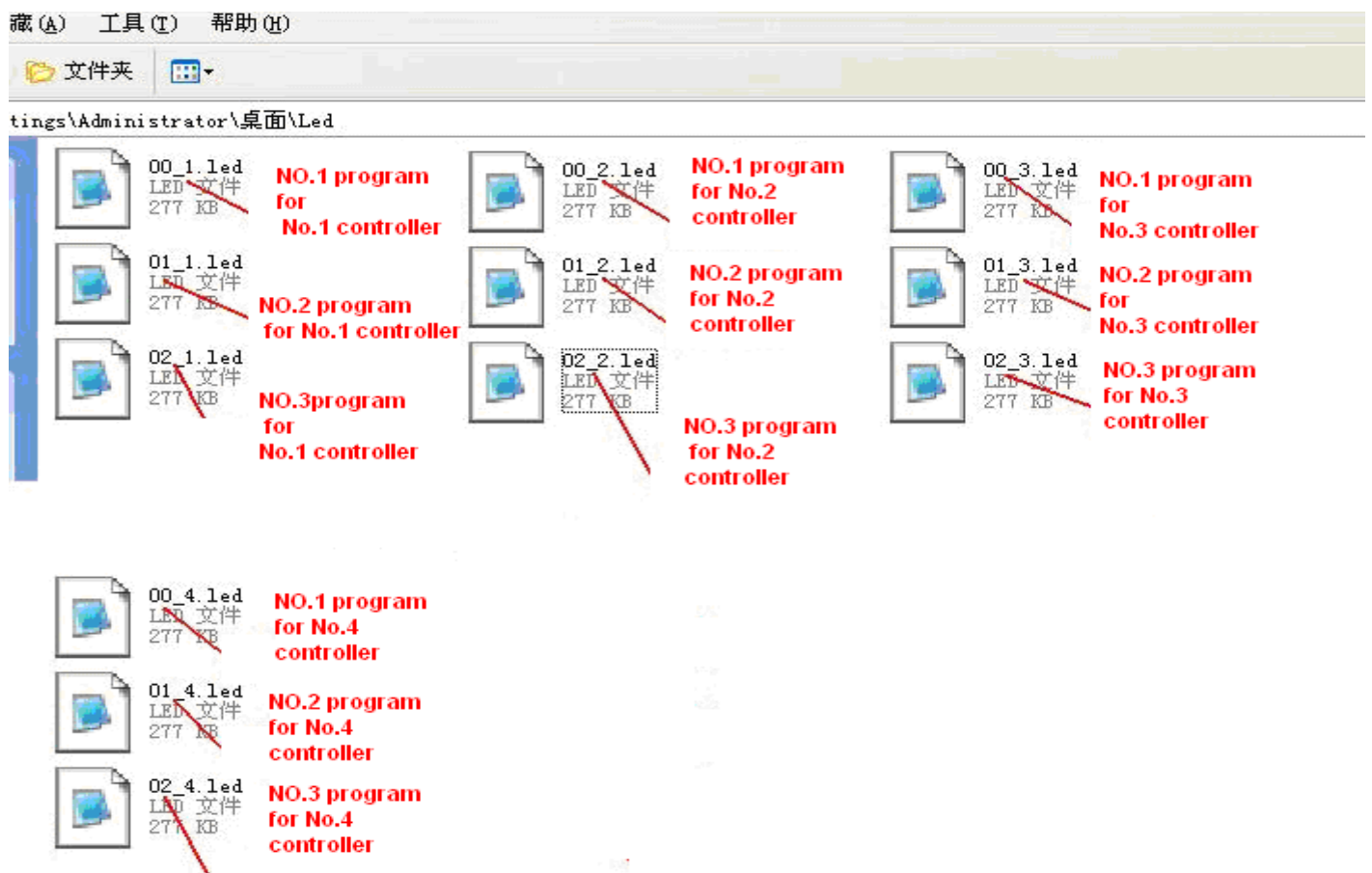

7、 Special parameters

Memory card :

type: SD card (suggest using high-speed SD card)

Capacity: 128MB—2GB

Format: FAT

Store file: *.led

Physical parameters:

Working temperature : -30°C—85°C

Working voltage: DC5V / DC7.5-24V

Working power: 1W

size: L165mm×W80mm×H30mm

weight: 0.35KG

signal port: 3pin connect port

Note:

Before copy files to SD card , The SD card must be formatted as FAT format

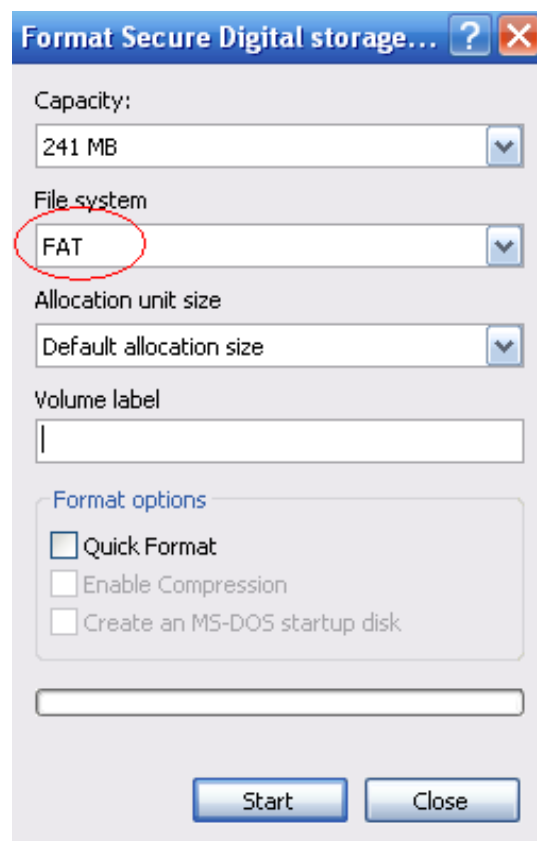

The SD card in controller can not be hot-swappable, plug the SD card every time, you must first disconnect the power supply

7、 Trouble shooting

Question 1: After power, the T-1000S ERROR indicator has been flashing without display output

answer: The ERROR indicator has been flashing means the controller did not read the card correctly, possible problems:

- ①SD card is empty, with no effect file.
- ②The effect file in the SD card and the controller model are not match, please choose correct controller model in LedEdit and then re-create the effect file *.led.
- ③SD card did not format to FAT before copy effect files.
- ④Please check the supply power voltage, the controller can be individually powered to exclude power reasons
- ⑤Changing the SD card and then test to exclude the possibility of a bad SD card

Question 2: The controller is powered on, the indicator is normal, but the lamps have no effect change

Answer: The reasons for this are as follows:

- ① Check if the lighting's signal line and the controller connected correctly
- ② If the TTL signal is received, the lamp and the controller must be common ground, that means connect the lighting's and the controller's ground together
- ③ Check if the model chose during making display files on the SD card match the chips used in the lighting